



Model: 121014-13



DESCRIPTION

- Two stage
- 230 volt
- 7.2" / 183 mm diameter
- Dual 10mm ball bearings
- Tangential discharge
- All aluminum die cast housings used in motor construction

DESIGN APPLICATION

- Equipment operating in environments requiring separation of working air from motor ventilating air
- Designed to handle clean, dry, filtered air only

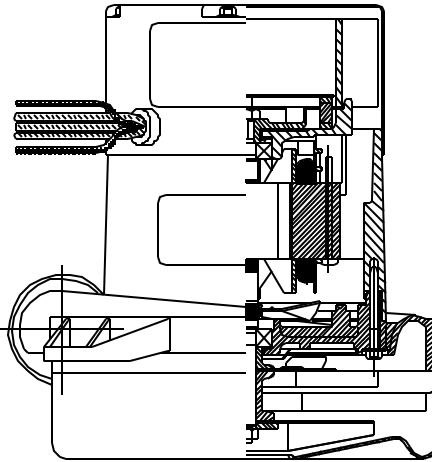

SPECIAL FEATURES

- Suitable for 230 volt AC operation, 50/60 Hz
- UL component recognized
- **Speed control capability**
 - Speed controlled fan system
 - Switchless Switched Reluctance Design
 - Intrinsically protected motor design
 - Protected air seal bearing construction (U.S. Patent # 4,088,424)
 - Epoxy painted
 - Minimum fan end bracket designed to dampen vibration and improve durability

Please refer to SR Blower Application Notes (listed below) for details on the operation and wiring of our SR speed control motor.

TYPICAL MOTOR PERFORMANCE.*

(At 230 volts, 60Hz, test data is corrected to standard conditions of 29.92 Hg, 68° F.)

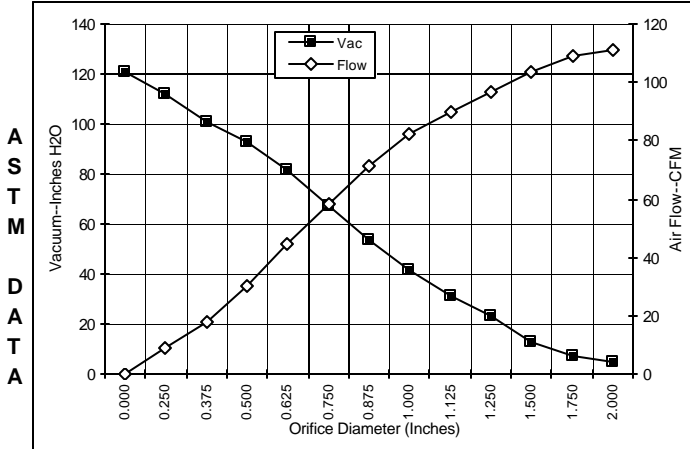

Orifice (Inches)	Amps	Watts (In)	RPM	Vac (In.H ₂ O)	Flow (CFM)	Air Watts
2.000	7.1	1349	21910	4.6	111.4	60
1.750	7.1	1367	21860	7.5	109.1	97
1.500	7.2	1375	21740	13.0	103.8	159
1.250	7.2	1379	21615	23.3	96.6	265
1.125	7.2	1384	21565	31.1	90.0	329
1.000	7.2	1376	21665	41.7	82.1	403
0.875	7.1	1360	21865	54.0	71.4	453
0.750	6.8	1312	22105	67.5	58.5	464
0.625	6.5	1264	22670	81.4	44.4	424
0.500	6.1	1171	23625	92.7	30.2	329
0.375	5.5	1073	24660	101.2	17.8	212
0.250	5.4	1043	26130	111.9	8.6	113
0.000	4.9	964	27000	120.7	0.0	0

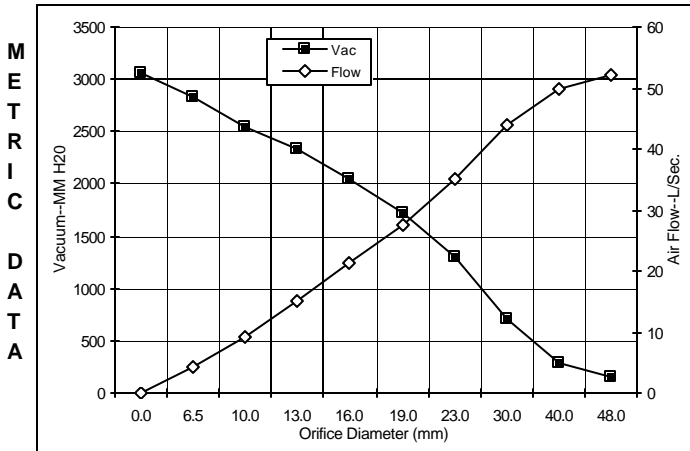

Orifice (mm)	Amps	Watts (In)	RPM	Vac (mm H ₂ O)	Flow (L/Sec)	Air Watts
48.0	7.1	1357	21888	149	52.1	76
40.0	7.2	1373	21776	288	49.7	140
30.0	7.2	1382	21588	701	43.9	300
23.0	7.1	1364	21815	1293	35.0	441
19.0	6.8	1311	22116	1722	27.5	463
16.0	6.5	1266	22647	2053	21.2	426
13.0	6.1	1180	23530	2326	14.9	339
10.0	5.6	1088	24505	2538	9.3	230
6.5	5.4	1045	26057	2829	4.3	118
0.0	4.9	964	27000	3066	0.0	0

Note: Metric performance data is calculated from the ASTM data above.

* Data represents performance of a typical motor sampled from a large production quantity. Individual motor data may vary due to normal manufacturing variances.

Test Specs: TBD	Minimum Sealed Vacuum: TBD	ORIFICE: 7/8"	Minimum Vacuum: TBD	Maximum Watts: TBD
-----------------	----------------------------	---------------	---------------------	--------------------



DIMENSIONS

- NOTES**
1. LEADS: 18 GA STRANDED, POWER LEADS ONE BLACK AND ONE WHITE, GROUND LEAD GREEN WITH YELLOW STRIPE.
 2. MOTOR IDENTIFICATION: MANUFACTURER'S NAME, MODEL NUMBER, VOLTAGE, FREQUENCY, INSPECTOR'S CODE, DATE OF MANUFACTURE, AGENCY REGISTRATION CODE, PLANT LOCATION CODE, THERMALLY PROTECTED LAMB, MADE IN THE USA AND THE FOLLOWING PART NUMBER: MANUFACTURED UNDER PART NOS. US5789893, TW81993, SG38957, ZA96/2766, US5760519, EP0702448B1, ZA95/7123 UNDER LICENSE FROM SWITCHED RELUCTANCE DRIVES LTD. OTHER U.S. AND FOREIGN PATENTS PENDING. COPYRIGHT CODE 1998. ALL RIGHTS RESERVED.
 3. MOUNTING MUST NOT RESTRICT THIS DIMETER.
 4. ALLOW 10.00±0.50 W/±0.50 IN. (MIN) FOR COOLING AIR INTAKE.
 5. COOLING AIR INTAKE MUST BE SEPARATED FROM COOLING AIR EXHAUST.
 6. COOLING AIR EXHAUST MUST BE SEPARATED FROM VACUUM EXHAUST.
 7. OBSERVE NEC WIRING CONVENTION (BLACK-LINE AND WHITE-NEUTRAL) TO INSURE PROPER PLACEMENT OF CONTROL MODULE FUSE IN THE CIRCUIT.

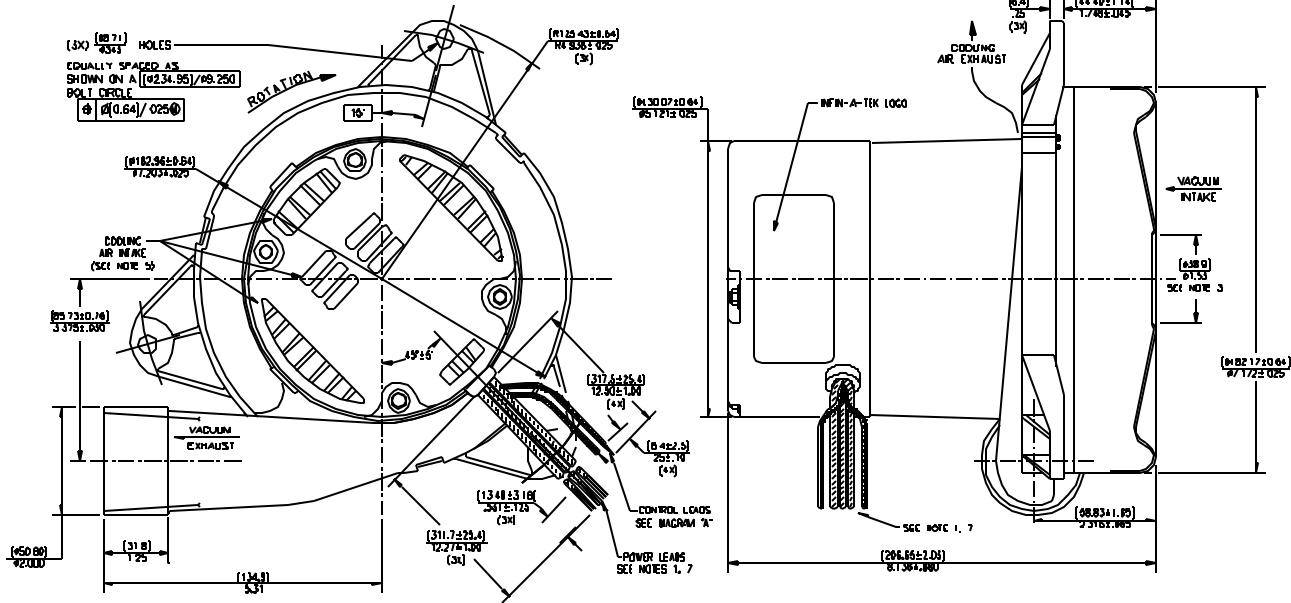
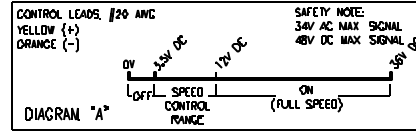

All switched reluctance motors are thermally protected using an auto-reset device, which is rated for 80 degrees C (maximum temperature limit)

(230v) AC Power Input
208v - 265v Nominal Operating Voltage

Manufactured under Patent nos. US5789893, TW81993, SG38957, ZA96/2766, US5760519, EP0702448B1, ZA95/7123 under license from Switched Reluctance Drives Ltd. Other US and foreign patents pending. Copyright code 1998. All rights reserved.

IMPORTANT NOTES: Pictorial and dimensional data are subject to change without notice. Contact factory for current revision levels.

WARNING - When using AMETEK/Lamb Electric bypass motors in machines that come in contact with foam, liquid (including water) or other foreign substances, the machine must be designed and constructed to prevent those substances from reaching the fan system, motor housing and electrical components. Lamb vacuum motors other than hazardous duty models should not be applied in machines that come in contact with dry chemicals or other volatile materials. Failure to observe these precautions could cause flashing (depending on volatility) or electrical shock which could result in property damage and severe bodily injury, including death in extreme cases. All applications incorporating Lamb motors should be submitted to appropriate organizations or agencies for testing specifically related to the safety of your equipment.



Switched Reluctance Blower Application Notes



Page 1

Lamb Electric Infin-A-Tek (SR) Blower User's Guide

The INFIN-A-TEK blower utilizes a switched reluctance (SR) brushless motor, which is commutated electronically. Similar to a brush type series universal motor, the INFIN-A-TEK (SR) blower operates from AC line voltage (**208v -265v nominal voltage**). However, the INFIN-A-TEK (SR) blower features an integral electronic control module that rectifies the "AC line voltage" to obtain the DC voltage required to power the motor.

The INFIN-A-TEK (SR) blower contains an imbedded microprocessor which controls the SR motor. This feature allows for the addition of an electronic "SPEED CONTROL", which allows the user to remotely control the speed of the blower. Speed control is obtained by use of a low voltage signal (provided by the customer) and can be in the form of either an AC, or DC signal (34V and 48V maximum respectively). The signal voltage tells the motor when to turn on, and also at what speed to operate. It is important to note the SR motor requires a minimum of 3.5V to start the motor, and reaches full speed at 12V. Our "SPEED CONTROL" will present a maximum 20 milliamp load to the control signal voltage. Please consult our wiring diagram listed below for specific wiring details.

Please review the diagram below carefully. The connection of the wires from the blower must be in accord with this sketch for the unit to operate properly.

SWITCHED RELUCTANCE "AC" BLOWER DIAGRAM

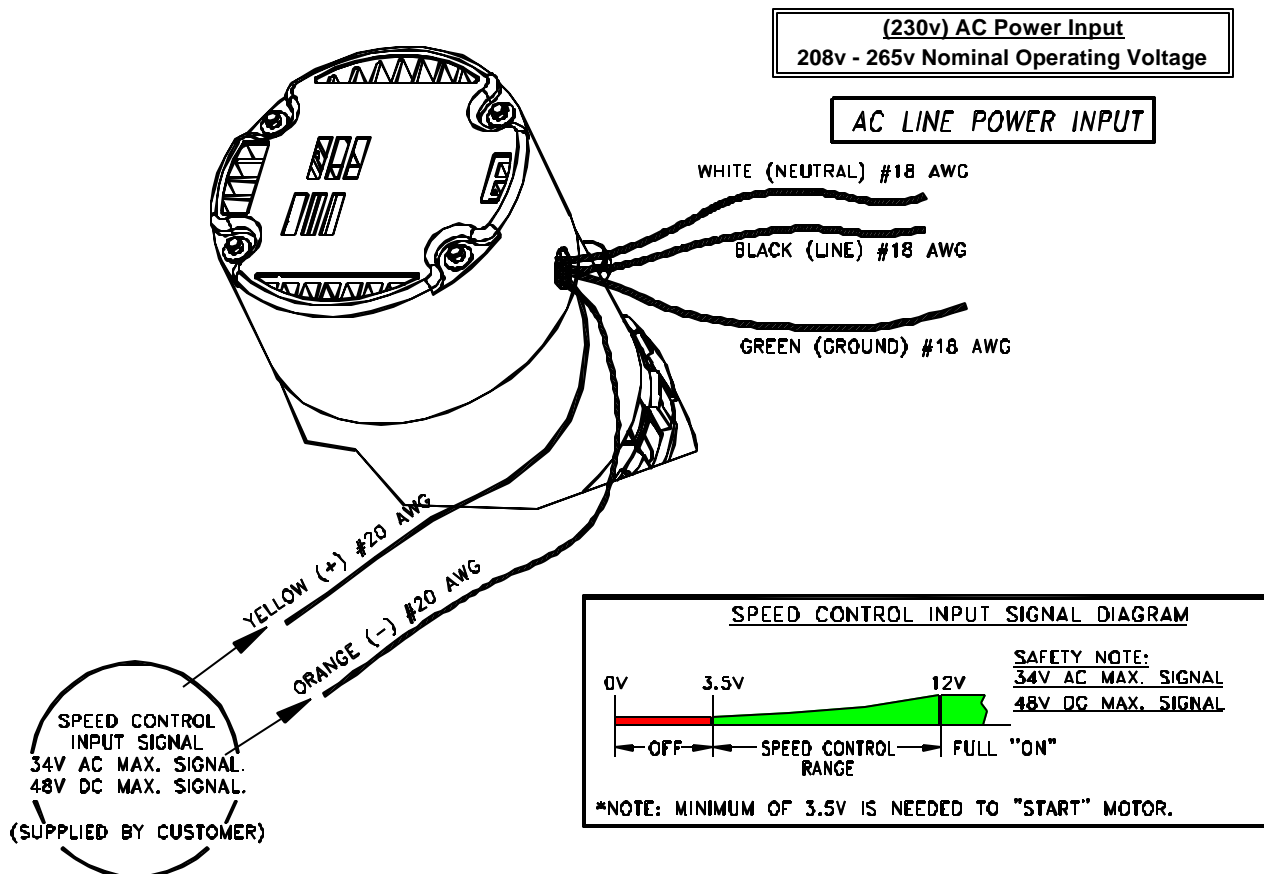

1. Motor "SPEED CONTROL" can be obtained by supplying either **AC** (34V maximum) or **DC** (48V maximum) voltage signal to the motor control wires. The input signal should be applied to the Yellow (+) #20 awg and Orange (-) #20 awg control wires as shown in the above diagram. Failure to limit the above AC and DC input voltages could result in controller damage.

2. A minimum of 3.5V input signal is required to start the operation of the blower, and maximum speed is reached at 12V.

All switched reluctance motors are thermally protected using an auto-reset device, which is rated for 80 degrees C (maximum temperature limit)



Switched Reluctance Blower Application Notes Continued



Page 2

Lamb Electric Infin-A-Tek (SR) Blower User's Guide

NOTE: The customer's vent cover must allow for a minimum of 4.0 square inches of cooling area to provide adequate motor cooling

NOTE: Motor mounting must not restrict air inlet ports on motor cover

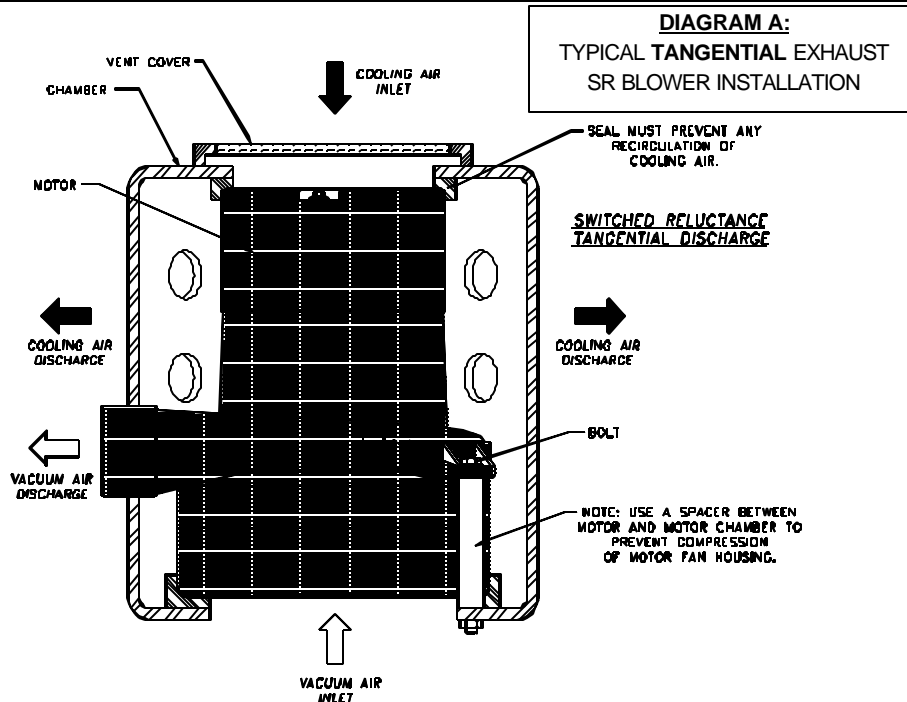

NOTE: The customer's vent cover must allow for a minimum of 4.0 square inches of cooling area to provide adequate motor cooling

NOTE: Motor mounting must not restrict air inlet ports on motor cover

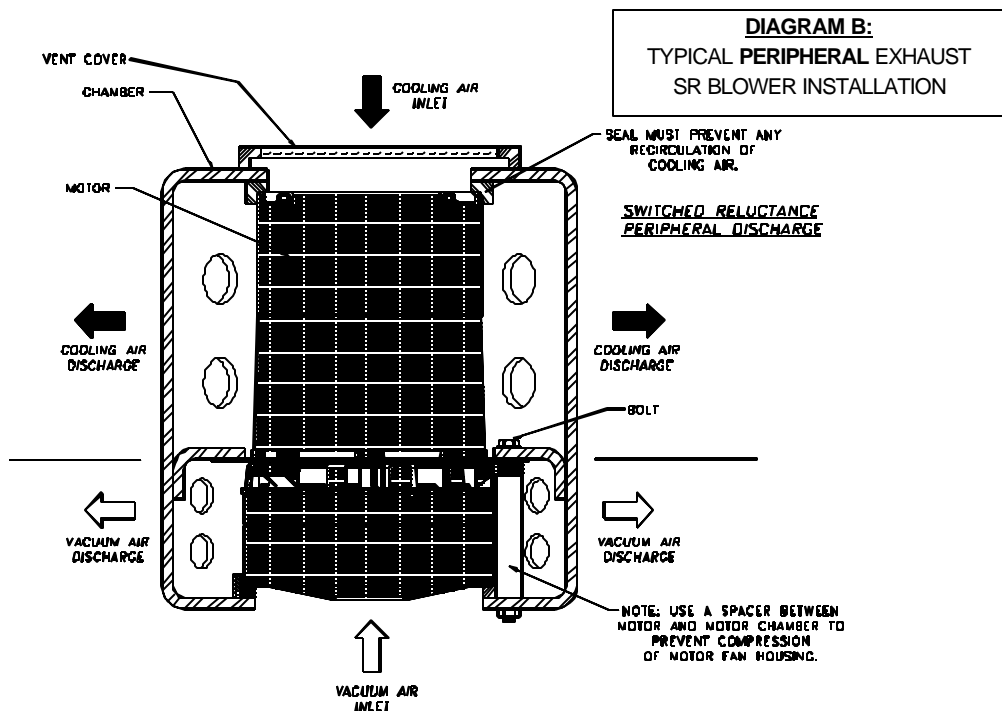

Installation Notes / Recommendations:

The above diagrams (A & B) provide "typical" installation recommendations for the application of Infin-A-Tek (SR) tangential exhaust and peripheral exhaust blower products. This information illustrates the required separation of "working / vacuum air" and "cooling air" within the above product enclosure. The separation of "working / vacuum air" and "cooling air" is essential to maintaining the extended life of the SR blower motors. Prolonged exposure of the motor's electronics to elevated temperatures, is not recommended.

**AMETEK/Lamb Electric Division
627 Lake Street
Kent, Ohio 44240 (U.S.A)
Tel: (330) 673-3451 Fax: (330) 673-8994**

Issued: November, 2003