

LAMB ELECTRIC

Model: 115962

DESCRIPTION

- Two stage
- 120 volts
- 7.2"/183 mm diameter
- Double ball bearings
- Single speed
- Peripheral bypass discharge
- Aluminum fan end bracket
- Aluminum commutator bracket

DESIGN APPLICATION

- Equipment operating in environments requiring separation of working air from motor ventilating air
- Designed to handle clean, dry, filtered air only

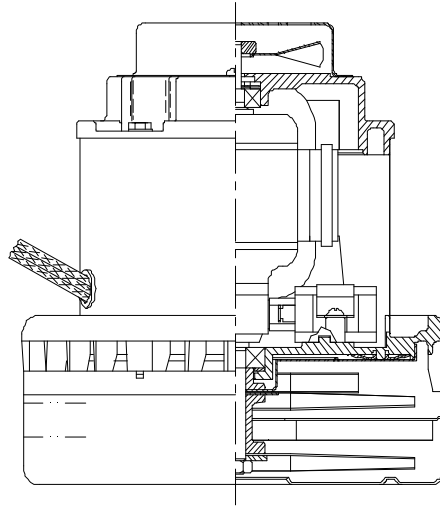

SPECIAL FEATURES

- Suitable for 120 volt AC operation, 50/60 Hz
- UL recognized, category PRGY2 (E47185)
- CSA certified, class 1611 01 (LR31393)
- Provision for grounding
- Epoxy painted fan case
- Patented air seal bearing protection. U.S. Patent # 4,088,424
- The Lamb Electric vacuum motor line offers a wide range of performance levels to meet design needs

TYPICAL MOTOR PERFORMANCE.*

(At 120 volts, 60Hz, test data is corrected to standard conditions of 29.92 Hg, 68° F.)

ASTM DATA

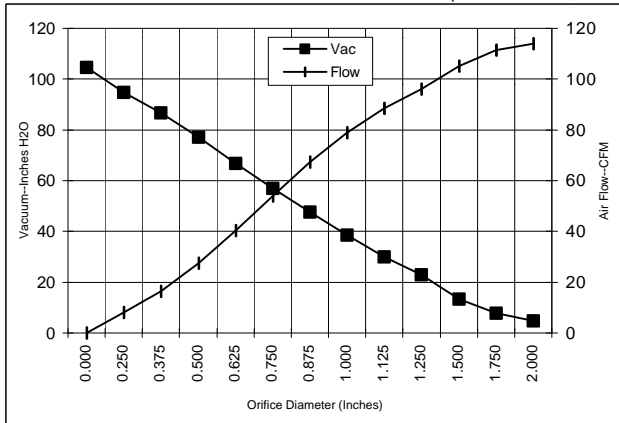

Orifice (Inches)	Amps	Watts (In)	RPM	Vac (In.H ₂ O)	Flow (CFM)	Air Watts
2.000	13.6	1469	16367	4.8	113.9	64
1.750	13.7	1478	16310	7.8	111.4	103
1.500	13.7	1482	16242	13.3	105.1	165
1.250	13.8	1498	16155	23.0	96.0	260
1.125	13.9	1498	16132	29.9	88.4	311
1.000	13.8	1488	16182	38.5	79.0	357
0.875	13.5	1461	16372	47.7	67.2	376
0.750	13.0	1407	16717	57.1	53.9	361
0.625	12.3	1335	17272	66.9	40.4	318
0.500	11.4	1248	17975	77.1	27.6	250
0.375	10.4	1146	18805	86.6	16.5	168
0.250	9.6	1056	19642	94.8	8.0	89
0.000	8.9	989	20350	104.6	0.0	0

METRIC DATA

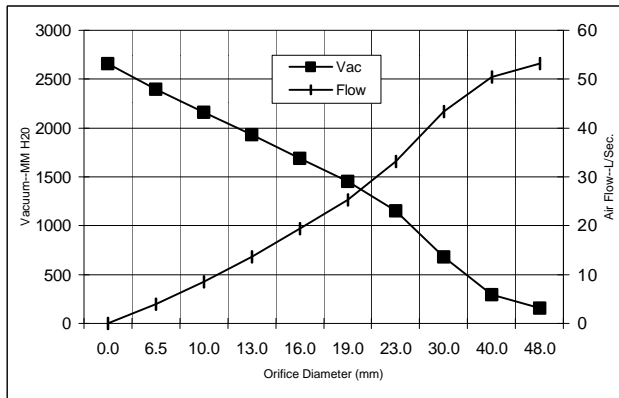

Orifice (mm)	Amps	Watts (In)	RPM	Vac (mm H ₂ O)	Flow (L/Sec)	Air Watts
48.0	13.6	1473	16327	155	53.2	81
40.0	13.7	1481	16327	296	50.5	146
30.0	13.8	1498	16194	681	43.3	288
23.0	13.6	1468	16170	1153	33.1	371
19.0	13.0	1406	16379	1455	25.3	360
16.0	12.3	1338	16703	1689	19.3	320
13.0	11.5	1257	17217	1932	13.6	257
10.0	10.6	1161	17870	2163	8.6	180
6.5	9.6	1061	18764	2398	4.0	93
0.0	8.9	989	20350	2657	0.0	0

Note: Metric performance data is calculated from the ASTM data above.

* Data represents performance of a typical motor sampled from a large production quantity. Individual motor data may vary due to normal manufacturing variations

Test Specs:	120 volts	Minimum Sealed Vacuum:	100.0"	ORIFICE:	7/8"	Minimum Vacuum:	43.0"	Maximum Watts:	1550
-------------	-----------	------------------------	--------	----------	------	-----------------	-------	----------------	------

DIMENSIONS

NOTES:

- 1. LEADS: POWER; #16 GA., ONE BLACK, ONE WHITE.
GROUND; #18 GA., GREEN WITH YELLOW STRIPE.

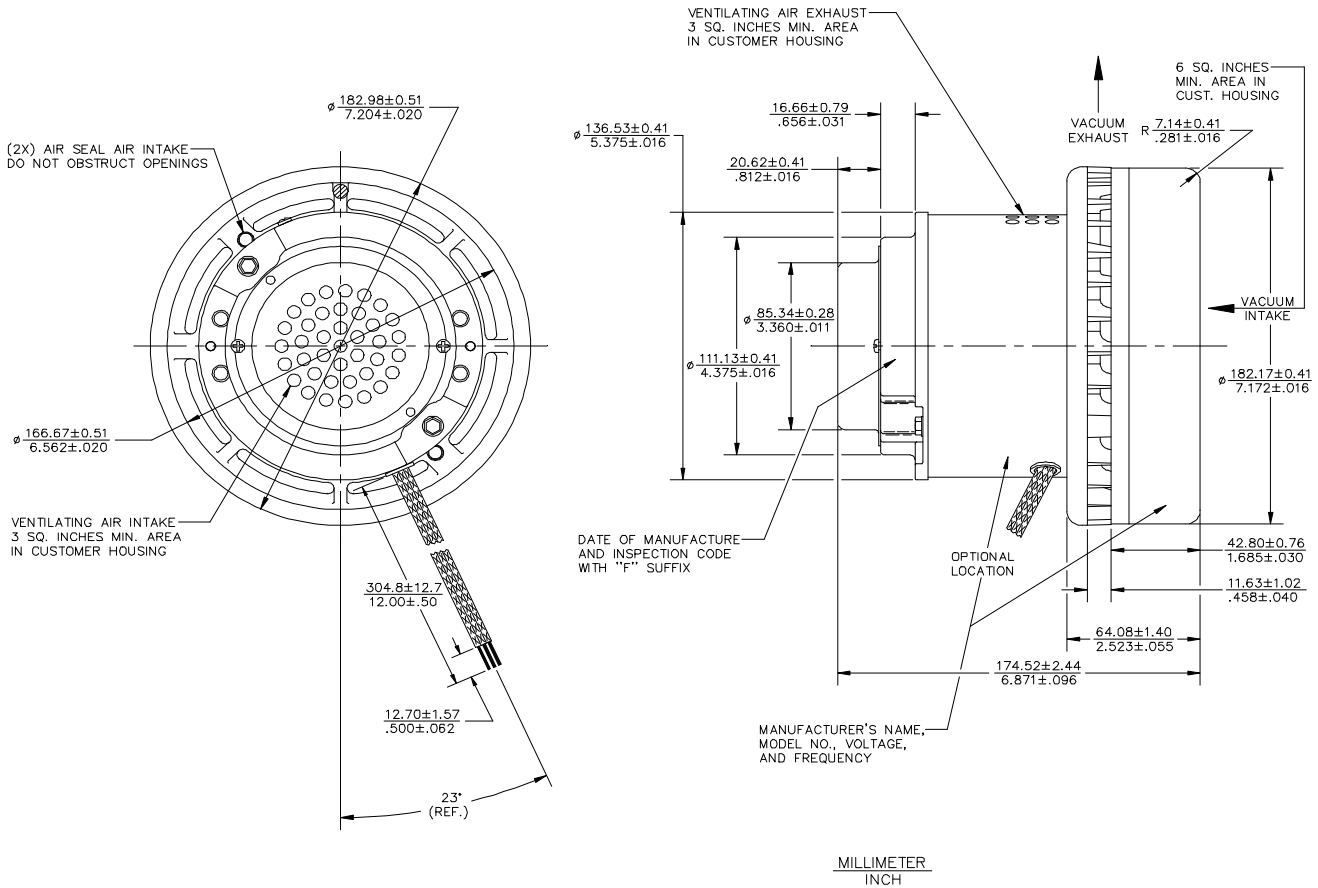

IMPORTANT NOTE: Pictorial and dimensional data are subject to change without notice. Contact factory for current revision levels.

WARNING - When using AMETEK Lamb Electric bypass motors in machines that come in contact with foam, liquid (including water), or other foreign substances, the machine must be designed and constructed to prevent those substances from reaching the fan system, motor housing, and electrical components. Lamb Electric vacuum motors other than hazardous duty models should not be applied in machines that come in contact with dry chemicals or other volatile materials. Failure to observe these precautions could cause flashing (depending on volatility) or electrical shock which could result in property damage and severe bodily injury, including death in extreme cases. All applications incorporating Lamb Electric motors should be submitted to appropriate organizations or agencies for testing specifically related to the safety of your equipment.

AMETEK Lamb Electric
627 Lake Street
Kent, Ohio 44240
U.S.A.
Tel: (330) 673-3451
Fax: (330) 673-8994

AMETEK GmbH
Dostojewskistrasse 10
D-65187 Wiesbaden
Germany
Tel: 49-0611-989210
Fax: 49-0611-9892110

AMETEK Singapore Pvt. Ltd.
10 Ang Mo Kio Street 65
05-12 Techpoint
Singapore 2056
Tel: 65-484-2388
Fax: 65-481-6588