

LAMB ELECTRIC

Model: 115334

DESCRIPTION

- Two stage
- 120 volts
- 7.2"/183 mm diameter
- Double ball bearings
- Single speed
- Tangential bypass discharge
- Aluminum fan end bracket
- Aluminum commutator bracket

DESIGN APPLICATION

- Equipment operating in environments requiring separation of working air from motor ventilating air
- Designed to handle clean, dry, filtered air only

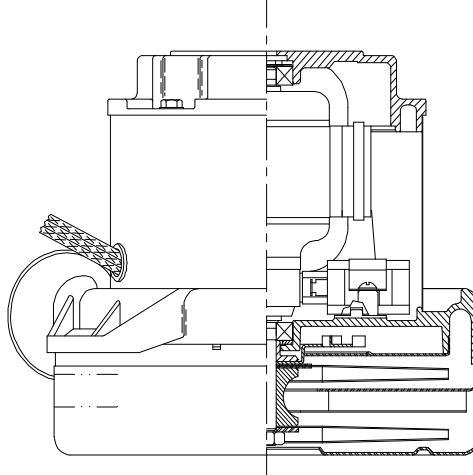

SPECIAL FEATURES

- Suitable for 120 volt AC operation, 60 Hz
- UL recognized, category PRGY2 (E47185)
- CSA certified, class 1611 01 (LR31393)
- Provision for grounding
- The Lamb Electric vacuum motor line offers a wide range of performance levels to meet design needs

TYPICAL MOTOR PERFORMANCE.*

(At 120 volts, 60Hz, test data is corrected to standard conditions of 29.92 Hg, 68° F.)

ASTM DATA

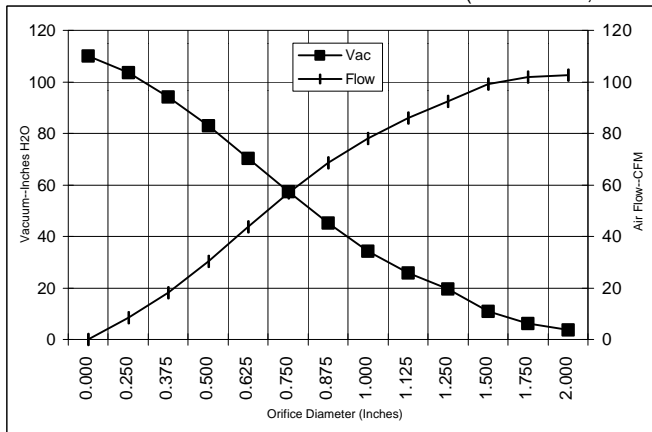

Orifice (Inches)	Amps	Watts (In)	RPM	Vac (In.H ₂ O)	Flow (CFM)	Air Watts
2.000	13.0	1440	16475	3.7	102.7	45
1.750	13.0	1440	16575	6.2	101.8	74
1.500	13.0	1444	16575	10.9	99.2	127
1.250	12.9	1436	16625	19.6	92.4	213
1.125	12.9	1420	16700	25.9	86.0	262
1.000	12.7	1408	16775	34.2	78.1	314
0.875	12.4	1380	17025	45.1	68.6	364
0.750	12.0	1332	17400	57.4	56.9	384
0.625	11.3	1272	18000	70.4	43.8	362
0.500	10.5	1192	18850	82.9	30.4	296
0.375	9.7	1112	19900	94.1	18.2	201
0.250	8.8	1008	20950	103.5	8.5	103
0.000	8.0	928	21800	110.0	0.0	0

METRIC DATA

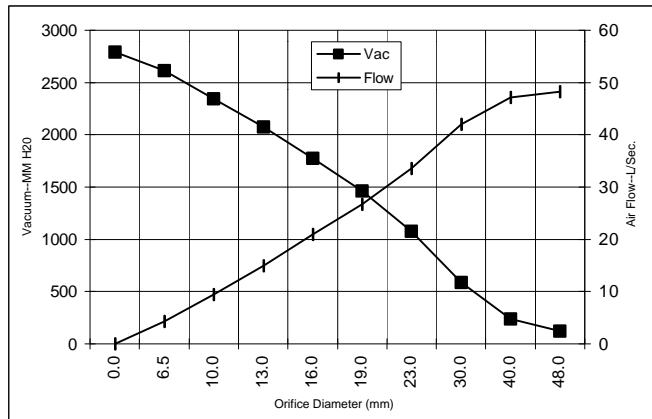

Orifice (mm)	Amps	Watts (In)	RPM	Vac (mm H ₂ O)	Flow (L/Sec)	Air Watts
48.0	13.0	1440	16519	122	48.3	58
40.0	13.0	1443	16575	241	47.2	111
30.0	12.9	1427	16666	586	42.0	240
23.0	12.5	1387	16963	1076	33.5	352
19.0	12.0	1331	17412	1465	26.7	384
16.0	11.3	1274	17976	1775	20.9	363
13.0	10.6	1200	18765	2074	15.0	303
10.0	9.8	1124	19743	2347	9.5	215
6.5	8.8	1013	20898	2617	4.2	108
0.0	8.0	928	21800	2794	0.0	0

Note: Metric performance data is calculated from the ASTM data above.

* Data represents performance of a typical motor sampled from a large production quantity. Individual motor data may vary due to normal manufacturing variations

Test Specs:	120 volts	Minimum Sealed Vacuum:	105.0"	ORIFICE:	7/8 "	Minimum Vacuum:	41.0"	Maximum Watts:	1500
-------------	-----------	------------------------	--------	----------	-------	-----------------	-------	----------------	------

DIMENSIONS

NOTES:

1. LEADS: POWER: #16 GA., ONE BLACK, ONE WHITE.
GROUND: #18 GA., GREEN WITH YELLOW STRIPE.

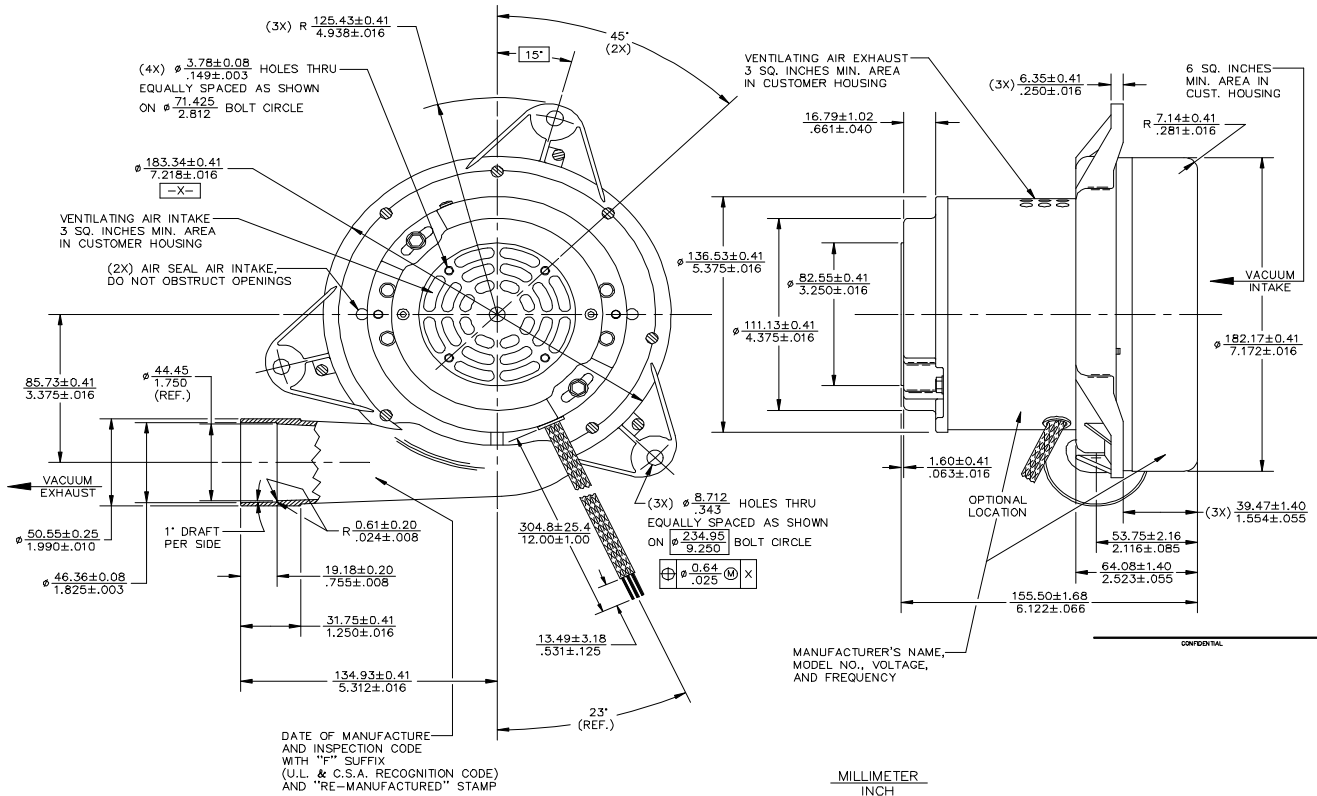

IMPORTANT NOTE: Pictorial and dimensional data are subject to change without notice. Contact factory for current revision levels.

WARNING - When using AMETEK Lamb Electric bypass motors in machines that come in contact with foam, liquid (including water), or other foreign substances, the machine must be designed and constructed to prevent those substances from reaching the fan system, motor housing, and electrical components. Lamb Electric vacuum motors other than hazardous duty models should not be applied in machines that come in contact with dry chemicals or other volatile materials. Failure to observe these precautions could cause flashing (depending on volatility) or electrical shock which could result in property damage and severe bodily injury, including death in extreme cases. All applications incorporating Lamb Electric motors should be submitted to appropriate organizations or agencies for testing specifically related to the safety of your equipment.

AMETEK Lamb Electric
627 Lake Street
Kent, Ohio 44240
U.S.A.
Tel: (330) 673-3451
Fax: (330) 673-8994

AMETEK GmbH
Dostojewskistrasse 10
D-65187 Wiesbaden
Germany
Tel: 49-0611-989210
Fax: 49-0611-9892110

AMETEK Singapore Pvt. Ltd.
10 Ang Mo Kio Street 65
05-12 Techpoint
Singapore 2056
Tel: 65-484-2388
Fax: 65-481-6588