

LAMB ELECTRIC

Model: 114786

DESCRIPTION

- Two stage
- 120 volts
- 7.5"/191 mm diameter
- Double ball bearings
- Single speed
- Peripheral bypass discharge
- Aluminum fan end bracket
- Aluminum commutator bracket

DESIGN APPLICATION

- Equipment operating in environments requiring separation of working air from motor ventilating air
- Designed to handle clean, dry, filtered air only

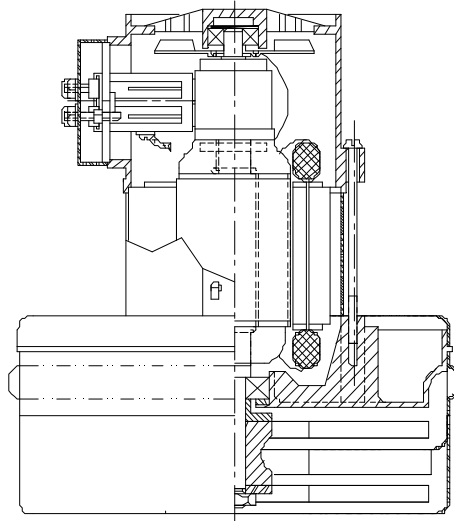

SPECIAL FEATURES

- Suitable for 120 volt AC operation, 50/60 Hz
- UL recognized, category PRGY2 (E47185)
- Provision for grounding
- The Lamb Electric vacuum motor line offers a wide range of performance levels to meet design needs

TYPICAL MOTOR PERFORMANCE.*

(At 120 volts, 60Hz, test data is corrected to standard conditions of 29.92 Hg, 68° F.)

ASTM DATA

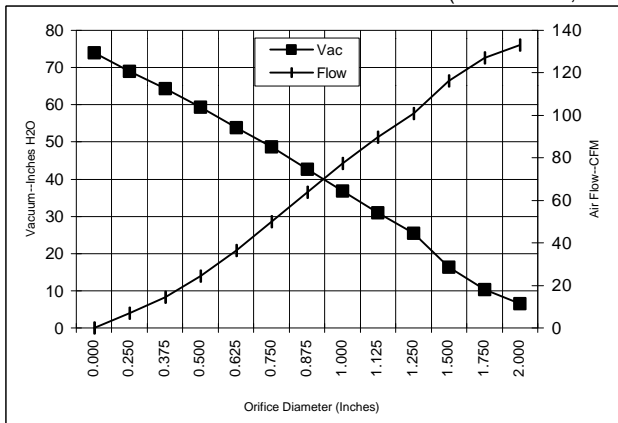

Orifice (Inches)	Amps	Watts (In)	RPM	Vac (In.H ₂ O)	Flow (CFM)	Air Watts
2.000	10.5	1155	18842	6.6	133.2	103
1.750	10.6	1163	18742	10.3	127.0	154
1.500	10.7	1174	18655	16.4	116.2	224
1.250	10.7	1178	18637	25.5	100.9	303
1.125	10.6	1167	18740	30.9	89.8	326
1.000	10.3	1144	19020	36.8	77.3	334
0.875	10.0	1103	19450	42.7	63.7	320
0.750	9.5	1056	20017	48.7	49.9	286
0.625	9.0	1002	20675	53.8	36.3	229
0.500	8.4	942	21460	59.3	24.3	169
0.375	7.9	884	22282	64.3	14.4	109
0.250	7.4	840	22990	69.0	6.9	56
0.000	7.1	806	23587	73.9	0.0	0

METRIC DATA

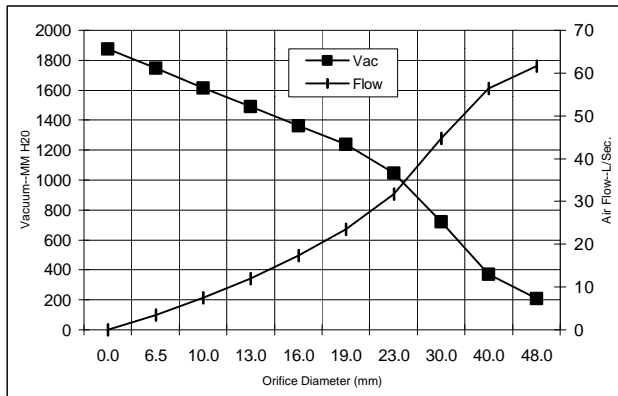

Orifice (mm)	Amps	Watts (In)	RPM	Vac (mm H ₂ O)	Flow (L/Sec)	Air Watts
48.0	10.5	1159	18798	209	61.6	125
40.0	10.6	1171	18681	370	56.4	203
30.0	10.6	1172	18694	723	44.7	316
23.0	10.1	1113	19343	1047	31.7	324
19.0	9.5	1055	20030	1240	23.4	285
16.0	9.0	1004	20649	1361	17.4	231
13.0	8.5	948	21382	1492	12.0	175
10.0	7.9	893	22159	1614	7.5	118
6.5	7.5	842	22955	1747	3.4	59
0.0	7.1	806	23587	1877	0.0	0

Note: Metric performance data is calculated from the ASTM data above.

* Data represents performance of a typical motor sampled from a large production quantity. Individual motor data may vary due to normal manufacturing variations

Test Specs:	120 volts	Minimum Sealed Vacuum:	69.0"	ORIFICE:	7/8"	Minimum Vacuum:	38.0"	Maximum Watts:	N/A
-------------	-----------	------------------------	-------	----------	------	-----------------	-------	----------------	-----

DIMENSIONS

NOTES:

1. GROUNDING OR EARTHING PROVISIONS: USE HOLES AS INDICATED FOR GROUNDING OR EARTHING. REFER TO APPROPRIATE LISTING OR REGULATORY AGENCY FOR PROPER METHOD OF GROUNDING OR EARTHING.

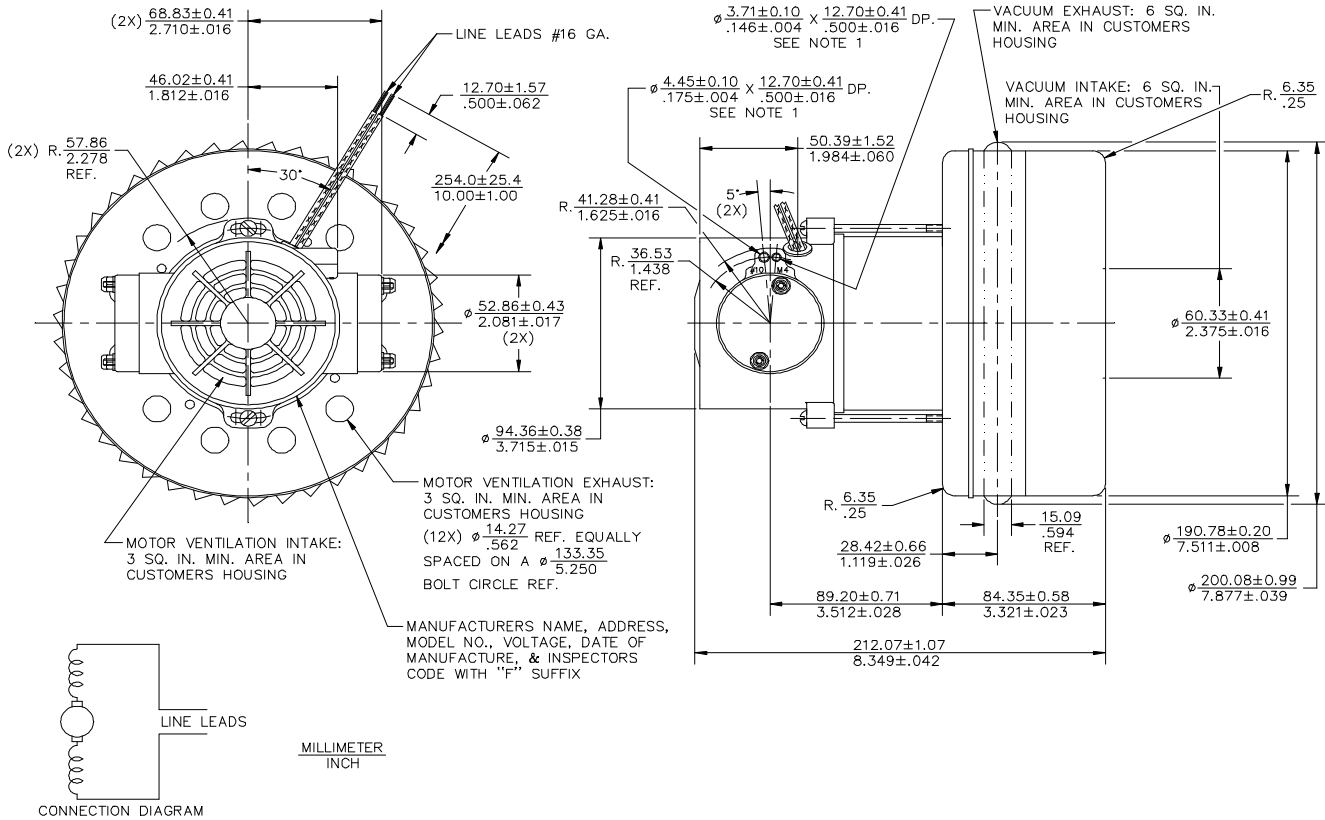

IMPORTANT NOTE: Pictorial and dimensional data are subject to change without notice. Contact factory for current revision levels.

WARNING - When using AMETEK Lamb Electric bypass motors in machines that come in contact with foam, liquid (including water), or other foreign substances, the machine must be designed and constructed to prevent those substances from reaching the fan system, motor housing, and electrical components. Lamb Electric vacuum motors other than hazardous duty models should not be applied in machines that come in contact with dry chemicals or other volatile materials. Failure to observe these precautions could cause flashing (depending on volatility) or electrical shock which could result in property damage and severe bodily injury, including death in extreme cases. All applications incorporating Lamb Electric motors should be submitted to appropriate organizations or agencies for testing specifically related to the safety of your equipment.

AMETEK Lamb Electric
 627 Lake Street
 Kent, Ohio 44240
 U.S.A.
 Tel: (330) 673-3451
 Fax: (330) 673-8994

AMETEK GmbH
 Dostojewskistrasse 10
 D-65187 Wiesbaden
 Germany
 Tel: 49-0611-989210
 Fax: 49-0611-9892110

AMETEK Singapore Pvt. Ltd.
 10 Ang Mo Kio Street 65
 # 05-12 Techpoint
 Singapore 2056
 Tel: 65-484-2388
 Fax: 65-481-6588